

# TECHNICAL GUIDE – BARCODE LABELLING ON PRIMARY- AND SECONDARY PACKAGES FOR PHARMACEUTICAL PRODUCTS

This technical guide was developed to help companies put correct barcodes on primary and secondary packages in order to meet the requirements for delivering pharmaceuticals to public hospitals in Denmark.

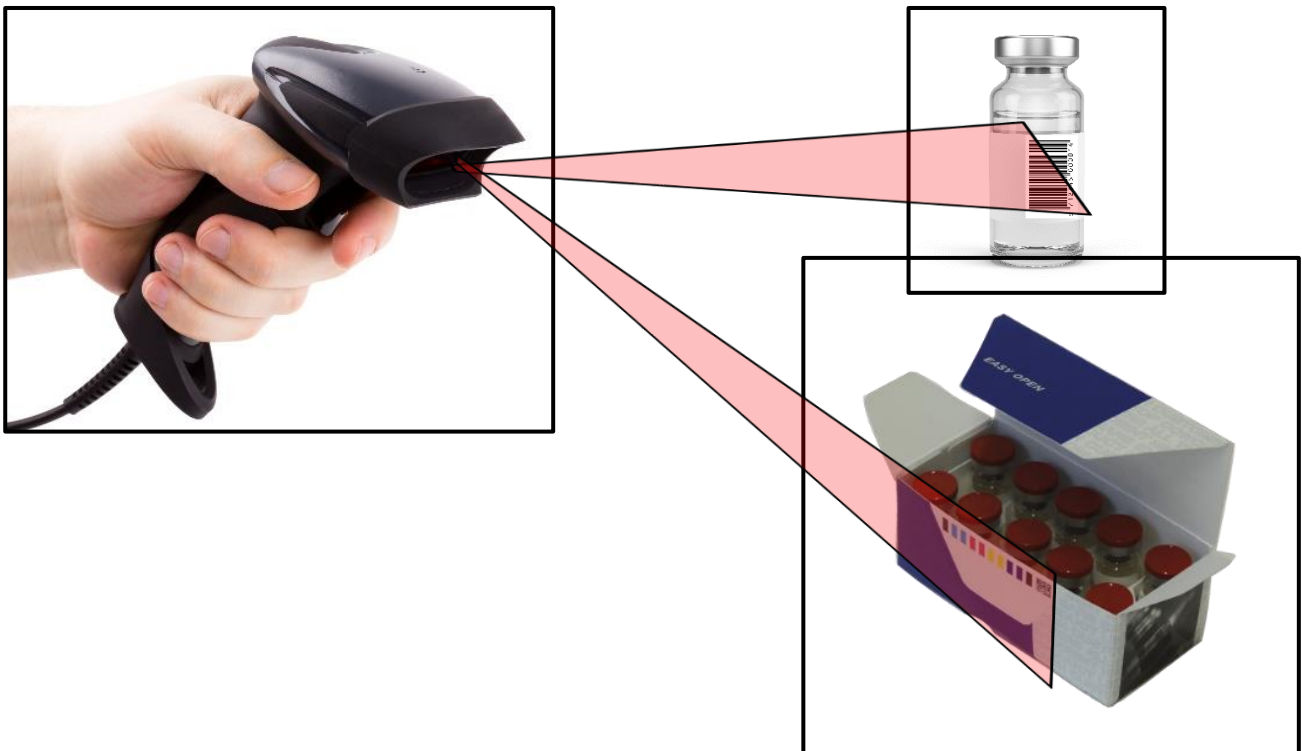

Content

- 1. Definition of primary package and secondary package ..... 3
- 2. Identification of pharmaceuticals ..... 4
  - 2.1 Allocation of Nordic Article Number ..... 4
  - 2.2 NTIN (National Trade Item Number) ..... 4
  - 2.3 GTIN (Global Trade Item Number) ..... 5
  - 2.4 The difference between NTIN and GTIN ..... 7
    - 2.5 Allocation of GTINs to primary- and secondary packages ..... 8
    - 2.6 When pharmaceutical products consist of powdered medication and a diluent ..... 9
    - 2.7 Indicator digit ..... 9
- 3. Barcode type, content and dimensions ..... 10
  - 3.1 The EAN-13 barcode ..... 10
  - 3.2 GS1 DataMatrix ..... 10
- 4. Serialization ..... 13
- 5. Barcode Quality ..... 14
- 6. General placement rules ..... 14
- 7. Colour and contrast ..... 16
- 8. Barcode label printing and environment ..... 17
- 9. Information about primary package identification to trading partners ..... 17
- 10. Information about secondary package identification to trading partners ..... 17
- 11. Amgros communication of product information to public hospitals ..... 17
- 12. References ..... 18
- 13. Appendix: Data structure for GS1 DataMatrix ..... 19

### 1. Definition of primary package and secondary package

The primary package (inner package) – the first level of packaging for the product marked with a barcode either on the packaging or on the label affixed to the packaging. The first level of packaging is the packaging in direct contact with the product.

NOTE: If the primary package is not contained in a box and thereby also constitutes the secondary package, the requirements for a barcode symbol on a secondary package must be complied with.

Figure 1: Examples of primary packages



Secondary package (outer package) – A level of packaging marked with a barcode that may contain one or more primary packages or a group of primary packages containing a single item.

Figure 2: Examples of secondary packages

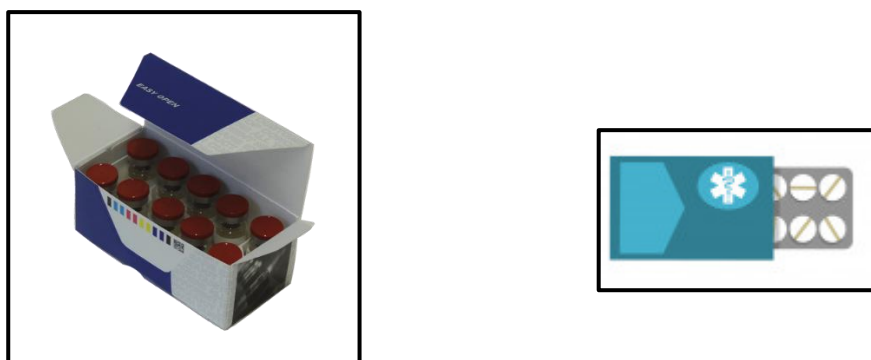

## 2. Identification of pharmaceuticals

### 2.1 Allocation of Nordic Article Number

When a pharmaceutical product has a marketing license, the holder of the marketing license or the representative of this must request a Nordic Article Number from the Pharmaceutical Information Center (PIC) in Finland <https://vnr.fi/>.

An assigned Nordic Article Number must only be used for one marketing license.

<https://www.retsinformation.dk/pdfPrint.aspx?id=182152> (Text in Danish)

The package must have a barcode containing a unique ID-number, which by scanning provides access to a database with information about the pharmaceutical product.

The manufacturer can use an NTIN or a GTIN. To learn more about NTIN and GTIN, see the below sections.

### 2.2 NTIN (National Trade Item Number)

A NTIN is a coding scheme, administered by PIC in Finland for which a prefix has been issued to permit its uniqueness within the GS1 pool, but without assurance of the full compatibility with GTIN functionality. In Denmark and the other Nordic countries the number begins with the Nordic prefix “704626” followed by the Nordic Article Number and ends with a check digit<sup>1</sup>.

It is no longer possible to request an NTIN for new pharmaceutical products. The NTINs which has been assigned before the 9<sup>th</sup> of February 2019, are still allowed to be used.

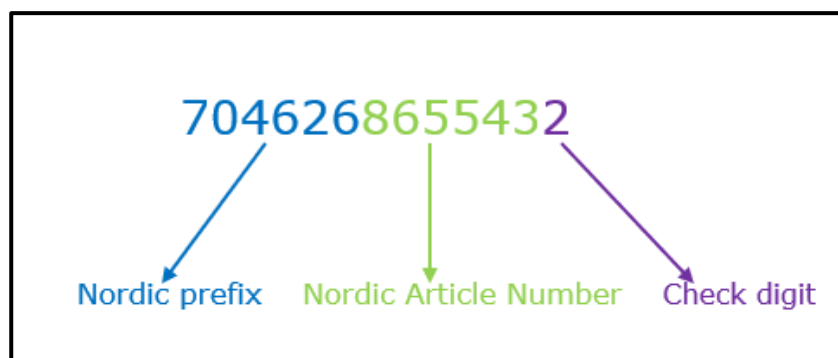

The allocation rules for the Nordic NTINs follow the Danish Medicines Agency allocation rules for Nordic Article Numbers. If the name of the product changes, then the Nordic Article Number changes, and therefore the NTIN.

Figure 3: Structure of the NTIN



<sup>1</sup> The check digit is calculated based on the first 12 numbers. The check digit can be calculated on <https://www.gs1.dk/support/beregning-dit-kontrolciffer/calculate-check-digits-for-barcodes/>

Figure 4: The link between Nordic Article Number, NTIN and barcode symbol

| Nordic Article Number | National Trade Item Number | Barcode symbols   |
|-----------------------|----------------------------|---|
| 865543                | 7046268655432              | <br> <br>(01) 07046268655432      (01) 07046268655432 |

Note: When a 13-digit NTIN is put in a GS1 DataMatrix, remember to add a leading zero, as the predefined length for Application Identifier (01) in a GS1 DataMatrix is 14 digits: e.g. 074676268655432.

### 2.3 GTIN (Global Trade Item Number)

When you become a member of a GS1 Organisation, you will get a GS1 company prefix, which is unique for every company. This number is used to generate a GTIN, which is the global unique product identification number. A GTIN consist of the GS1 company prefix, a product reference number (which the company chooses) and a check digit [1]. Allocation of GTINs follow the GS1 allocation rules [2]. If a product changes significantly, it requires a new GTIN.

Figure 5: Structure of the GTIN

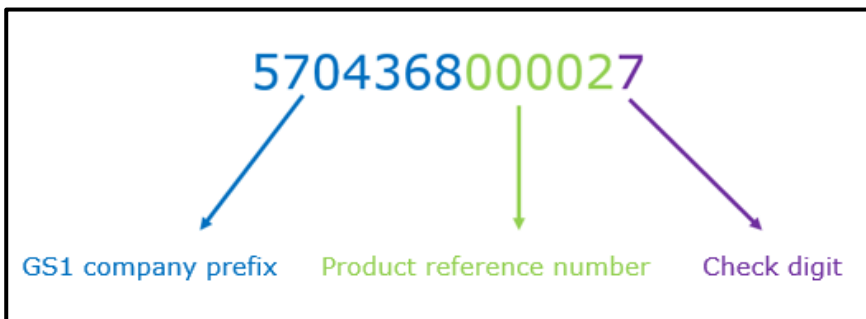





Figure 6: The link between Nordic Article Number, GTIN and barcode symbol

| Nordic Article Number | Global Trade Item Number | Barcode Symbols   |
|-----------------------|--------------------------|---|
| 865543                | 5704368000027            |   |
|                       |                          |   |
|                       |                          | (01)05704368000027      (01)05704368000027  |

Note: When a 13-digit GTIN is encoded in a GS1 DataMatrix, remember to add a leading zero, as the predefined length for Application Identifier (01) in a GS1 DataMatrix is 14 fields: 057043680000327.

Figure 7: Examples of assigning a new GTIN

The language on the product changes:

The pack size changes:

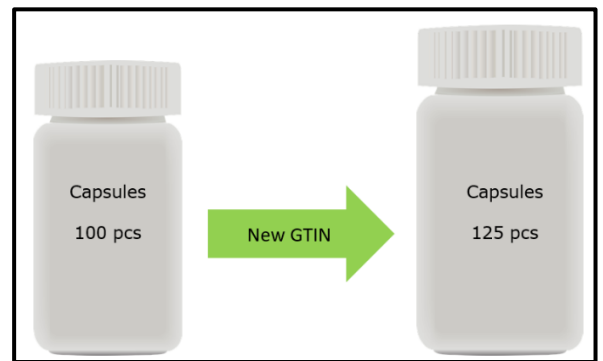
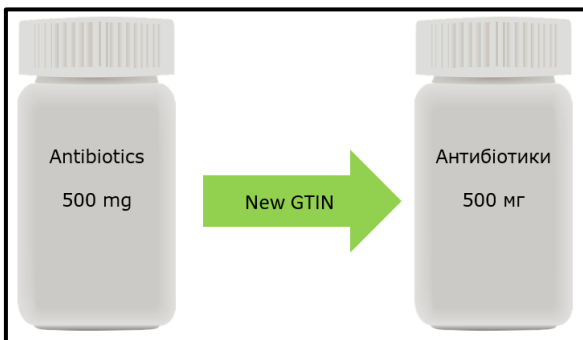

The above shown are just examples of when to assign a new GTIN to the product. To get a complete overview of the GTIN allocation rules, see GS1 Healthcare GTIN Allocation Rules [2].

## 2.4 The difference between NTIN and GTIN

NTIN is created from a national number, which can be encoded in a GS1 barcode and used in processes, but it is not a GS1 standard. GTIN is a globally unique number, which identifies products based on GS1 standards. NTIN follows the allocation rules for the Nordic Article Number, and changes only when the Nordic Article Number changes, whereas the allocation rules for GTIN are different. An example: if the packaging of a pharmaceutical product changes from a blister pack to a pill bottle. In this example, the Nordic Article Number will remain the same, which means that the NTIN will not change. However, this change in packaging will result in a new GTIN, see figure 8.

Figure 8: Example of the difference between NTIN and GTIN



A pharmaceutical product distributed to Denmark, Norway, and Sweden with leaflets in Danish, Norwegian and Swedish, respectively, can have the same Nordic Article Number and then the same NTIN. However, the three packages will have three different GTINs, see figure 9.

Figure 9: A pharmaceutical product with three different leaflets can have the same NTIN, but must have different GTINs

| Country | Nordic Article Number | NTIN          | GTIN          |
|---------|-----------------------|---------------|---------------|
| Denmark | 123456                | 7046261234569 | 5712345000014 |
| Norway  | 123456                | 7046261234569 | 5712345000021 |
| Sweden  | 123456                | 7040261234569 | 5712345000038 |

## 2.5 Allocation of GTINs to primary- and secondary packages

It is important that one GTIN identifies one product, and that a given product only has one GTIN. Primary packages must retain the same GTIN even though there are different quantities of primary packages within secondary packages. The GTIN of the secondary package must on the other hand vary, when the package contains 1, 3 or 5 primary packages, to be able to identify the various products uniquely, see figure 10.

Figure 10: Every syringing has the same GTIN, however, the different secondary packages have different GTINs

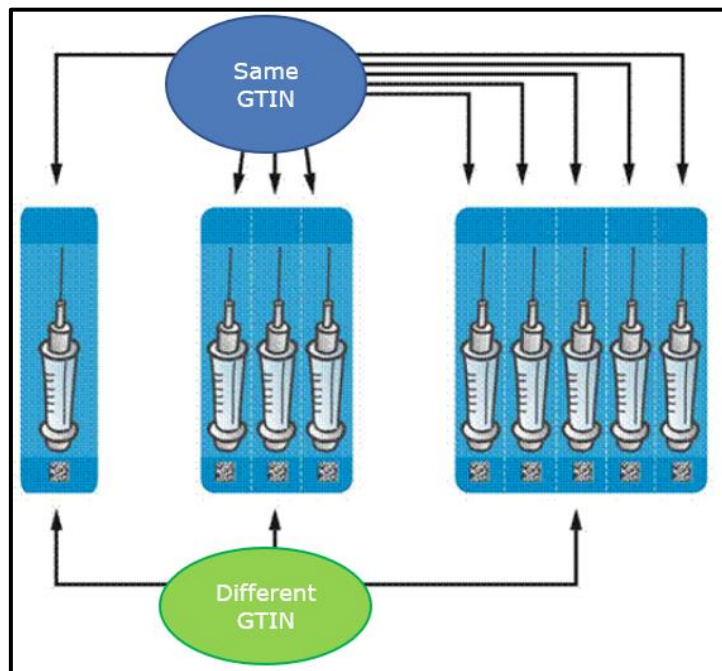



## 2.6 When pharmaceutical products consist of powdered medication and a diluent

Some pharmaceutical products consist of powdered medication and a diluent. Amgros does not require barcodes on the diluent, however, it is allowed. Since the secondary package contains two vials, it is not a 1:1 relationship, and the vial with the powdered drug must have a GTIN, and the package, which contains the powdered drug + the diluent, must have another GTIN, see figure 9.

Figure 9: Allocation of GTINs to packages which contain powdered drug + diluent

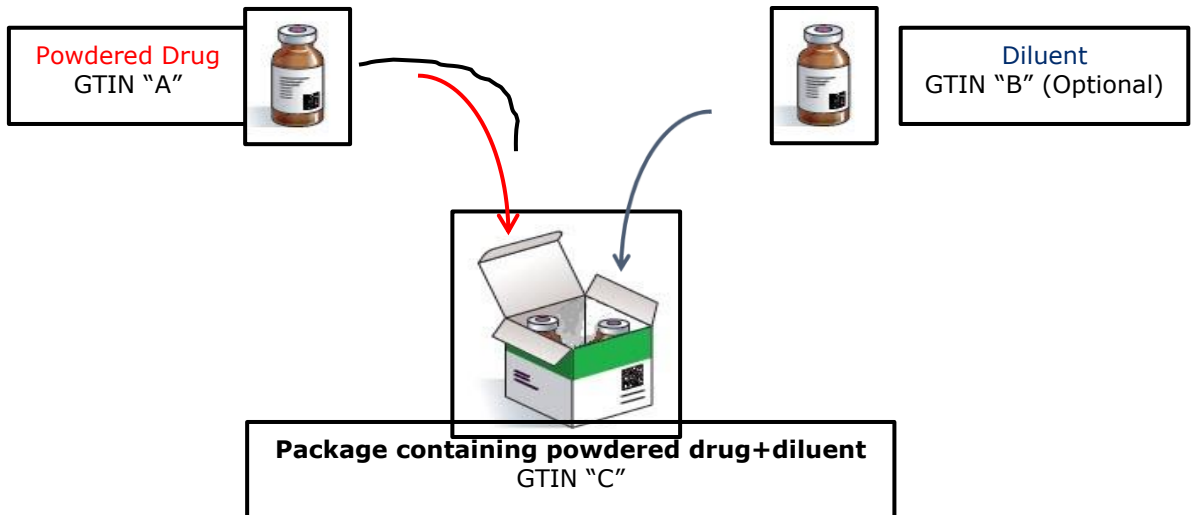

## 2.7 Indicator digit

The Indicator is a digit with a value of 1 to 8, which is placed in front of the GTIN-13 or NTIN-13. Hereby, a GTIN-14 or NTIN-14 is constructed. The manufacturer or supplier has the option of either assigning a unique GTIN-13 to each packaging level or a unique GTIN-14 with an indicator, see figure 12.

Figure 12: The use of Indicator digit

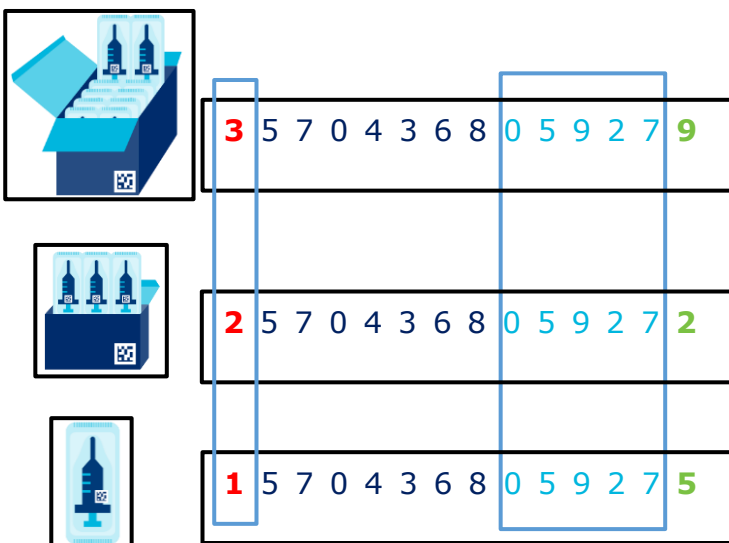

**Note:** The above is ONLY an example. It is the manufacture, who chooses the indicator digit between 1-8. Further notice, that the check digit for each variant is re-calculated.

### 3. Barcode type, content, and dimensions

#### 3.1 The EAN-13 barcode

The EAN-13 barcode contains only a 13-digit item number (NTIN/GTIN), see figure 13.

Figure 13: Example of EAN-13 barcode symbol



Dimensions:

When used the EAN-13 barcode symbol must not be smaller than 6 x 19 mm. An EAN-13 barcode, which measures 6 x 19 mm and can be scanned by the hospital's scanners is analogous to the barcode symbol on SAD vial labels.

**Note:** Amgros allows barcode dimensions of 6 x 19 mm for the EAN-13 barcode, which is a more truncated height than the recommendations in the GS1 General Specifications.

#### Quiet Zones:

It is important for the scanning process that there is a margin on both sides of the barcode – called a quiet zone, which contains no text or other information or graphics. The quiet zone defines where the barcode begins and where it ends. The size of the quiet zone depends on the dimensions of the barcode [1].

#### 3.2 GS1 DataMatrix

The GS1 DataMatrix barcode symbol is by definition a version of ISO/IEC 16022 DataMatrix with a Function Code 1 (FNC1) character in the first data position. This indicates to the scanner that the data encoded in the barcode follows the GS1 data format. GS1 General Specifications describes what data formats the various information contained in the barcode should have.

A GS1 DataMatrix can contain more information than just the GTIN (or NTIN) for example a batch/lot number, serial number, and/or expiration date.

Figure 14: Example of GS1 DataMatrix containing GTIN, Expiration date, Batch/Lot number and Serial number



**Note:** The parentheses must not be a part of the encoded data in the barcode but are only a part of the human readable text.

**Dimensions:**

A GS1 DataMatrix has two formats – a square format and a rectangular format. It depends on the size and shape of the product, amount of data to encode and the printing process which format is suitable for the product.

The minimum size for a GS1 DataMatrix is an X-dimension of 0.254 mm, where the X-dimension refers to height and width of a single module (square/dot) in a GS1 DataMatrix.

Figure 15: Minimum dimensions of a GS1 DataMatrix only containing a GTIN, and an X-dimension of 0.255mm



It is important for the scanning process, that there is a quite zone on all four sides of the GS1 DataMatrix, which is a field containing no text or graphics.

The dimension of the Quite Zone for a GS1 DataMatrix is 1 X-dimension on all four sides, see figure 15a (3).

Figure 15a: Quite Zone and x-dimension

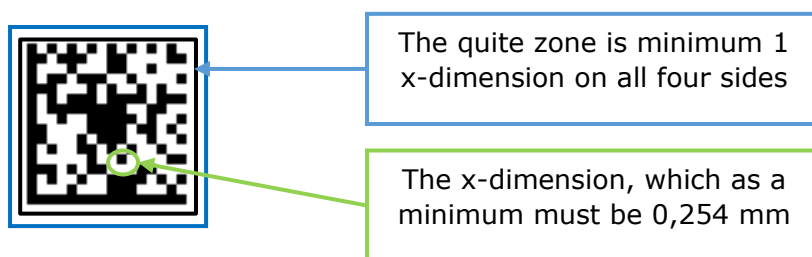

## Human readable interpretation

There are two formats of human readable text. The text related to the encoded data within the barcode (“human readable interpretation” or HRI), and all other text on the label (“non-HRI text”), which may be based on regulatory requirements, see figure 16.

The HRI for the data encoded within the barcode shall always be printed adjacent to the GS1 barcode, while protecting the quiet zones. In circumstances with extreme space constraints you can omit parts of, or all of the readable text related to the barcode, however, if possible, it is important to have the GTIN in readable text [1]. For the secondary package, the human readable text can be omitted, if the sum of the two largest length measures 10 centimetres or less [4].

Figure 16: Example of a label containing a GS1 DataMatrix, human readable interpretation and non-HRI text:

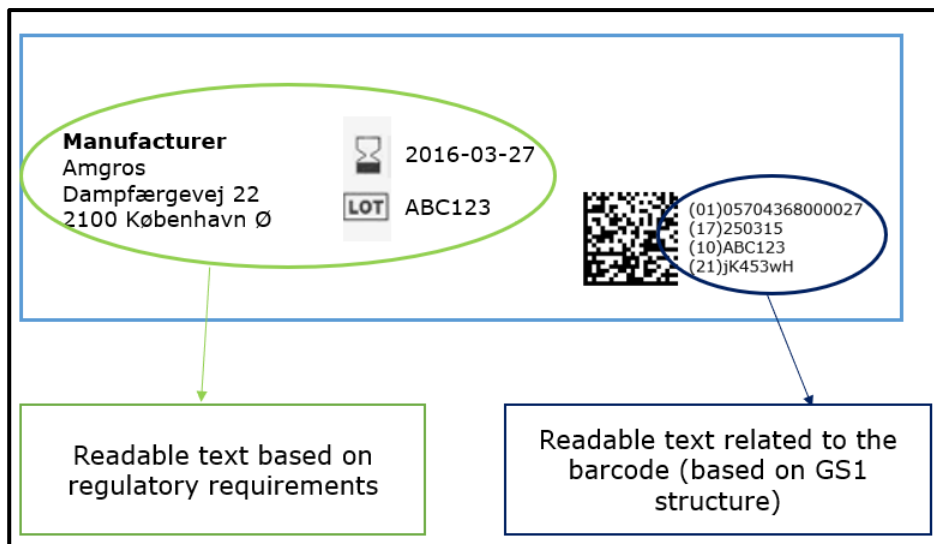

#### 4. Serialization

The 9<sup>th</sup> of February was the deadline for implementation of the Falsified Medicines Directive. This means that all prescription drugs sold to the European market must be uniquely identified with a global unique product number and a serial number. The requirements are only applicable to the sales unit (secondary package) and not the other packaging levels, which means that the secondary package must be marked with a 2D barcode containing: Product number (GTIN), expiry date, batch-/lot number and a randomised [4], see figure 17.

Figure 17: Primary and secondary packages after 9<sup>th</sup> of February 2019

##### Primary packages

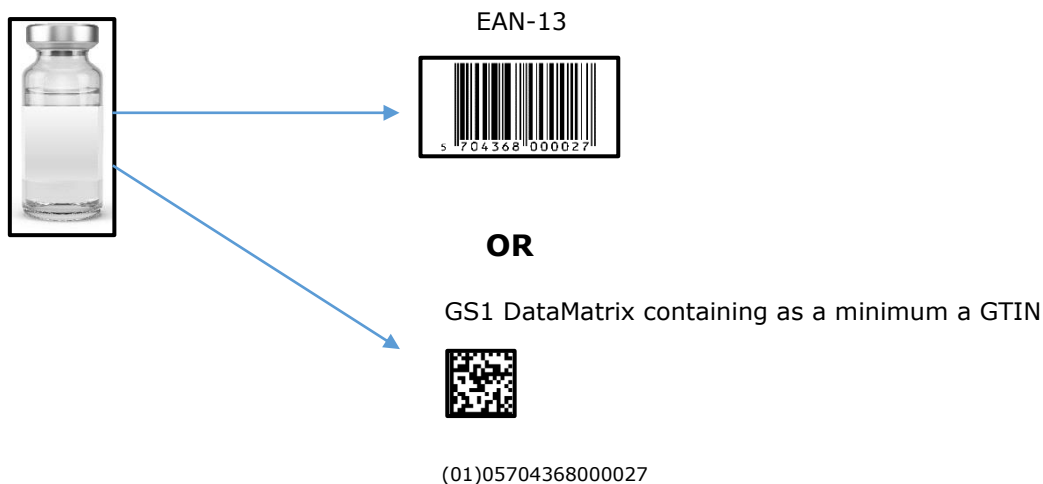

##### Secondary packaging

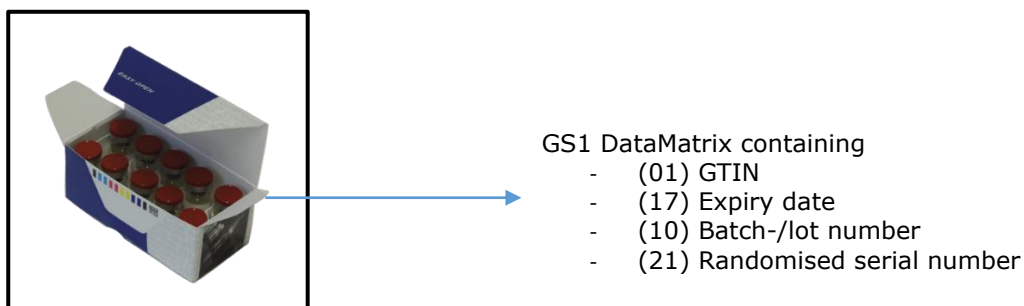

For information on serial number, expiry date, and batch-/lot number formats, see 13. Appendix.

## 5. Barcode Quality

Barcode symbols must be scannable at a satisfying level of performance through the expected life span of the product and through the whole supply chain. ISO/IEC 15416 defines a standardised methodology for measuring and grading linear barcodes like EAN-13, and ISO/IEC 15415 describes the standard for measuring and grading GS1 DataMatrix. The standards use a reporting system, which expresses the overall symbol grade by a digit between 0 and 4 or a letter between A and F.

According to GS1 General Specifications, both an EAN-13 and a GS1 DataMatrix must at least have an overall symbol grade of 1,5/C [1].

Figure 18: Quality Scale with both letters and digits

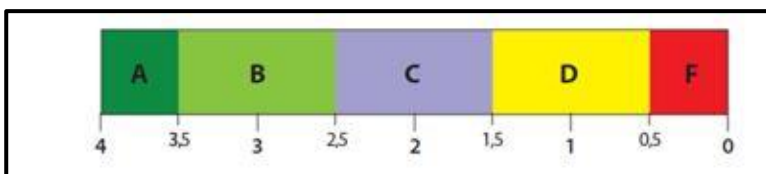

The Manufacturers who apply barcode symbols are responsible for meeting symbol quality requirements. Different equipment is available for checking the barcode quality, and it is important that the equipment also complies with all applicable standards [5,6,7].

Note: It is recommended to test the quality of the barcode symbol in its final configuration, such as when the label is on the product to ensure that noted quality is representative of how it will be perceived within the supply chain.

## 6. General placement rules

It is recommended that the barcode is placed on a plane surface and never around a corner, on a rim, at a welding seam or the like that will hinder or obscure the scanning of the symbol [1]. If the barcode is placed on a curved surface with a diameter less than 6 cm, it is recommended to have the EAN-13 barcode symbol in ladder orientation.

For GS1 DataMatrix, it is necessary that the scanner can image or “take a picture” of the whole barcode. To increase scannability it is recommended to place the GS1 DataMatrix on a plane surface, so that the barcode is not distorted or changed in size, shape, or colour, see figure 19.



Figure 19: Shape of a square GS1 DataMatrix

It is recommended to use a rectangular GS1 DataMatrix, if the barcode is placed on a small product, which has a curvature surface, see figure 20.

Figure 20: Rectangular versus square GS1 DataMatrix

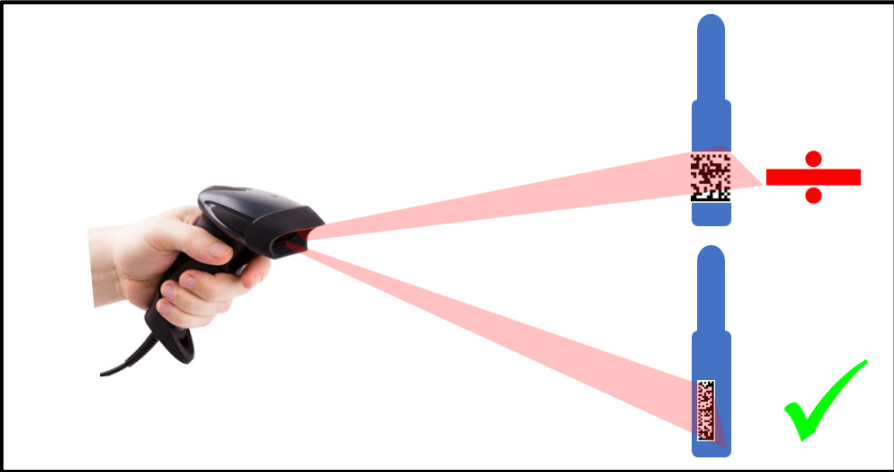

## 7. Colour and contrast

Scanners rely on the reflective contrast between the dark bars and light spaces (on a linear symbol like an EAN-13) to properly “see” and read the barcode.

To obtain maximum contrast it is recommended to print black lines on a white background. As a general rule, red, orange, and yellow can be used as background. Dark colours like black, blue, and green are considered useful for the dark bars in the barcode, see figure 21 on the next page.

Scanning of 2D barcodes uses image-technology. The same rules of maximum contrast are applicable, however, the option does exist to use light modules on a dark background.

Figure 21: Examples of colour combinations in linear barcodes which give maximum contrast, and examples of colour combinations, which will not be scannable.

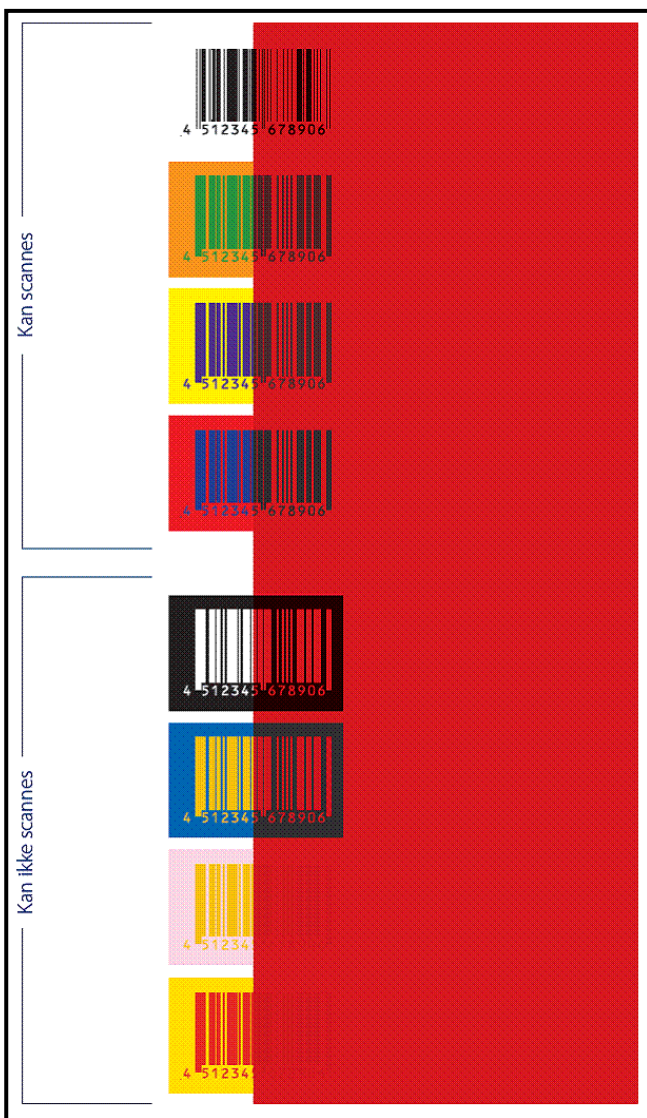



## **8. Barcode label printing and environment**

If a barcode label is used it is important to use a substrate material and an adhesive that suits the environment (e.g. humidity, cold, hot and room temperature) so the barcode is scannable throughout its life span and the label will not deteriorate and/or fall off.

If a barcode is printed directly on the product, it is important to use ink that in conjunction with the packaging material suits the environment (e.g. cold, hot and room temperature) ensuring that the barcode always can be scanned.

## **9. Information about primary package identification to trading partners**

A GTIN on the primary package must be linked to the product information on the secondary package. In the hospital sector, this is achieved by Amgros receiving the necessary information from the manufacturer or the marketing license holder and making this information available in a pharmaceutical database. The database is made accessible for hospital trading partners.

## **10. Information about secondary package identification to trading partners**

The secondary package, which is the sales unit, has a GTIN or NTIN and a Nordic Article Number. All related product information is linked to the Nordic Article Number and is communicated through Medicinpriser.dk. The database is accessible to hospital trading partners.

## **11. Amgros communication of product information to public hospitals**

Information about GTIN on primary and secondary packages must be registered on Amgros' tendering site [8].

ApoVision, which is the system behind the hospitals' dose dispensing, will also redistribute GTIN information on primary packages for use in wards, clinics and service production and other places in which safe pharmaceutical identification should take place.

## 12. References

1. GS1 General Specifications  
([http://www.gs1.org/docs/barcodes/GS1\\_General\\_Specifications.pdf](http://www.gs1.org/docs/barcodes/GS1_General_Specifications.pdf))
2. GS1 Healthcare GTIN Allocation Rules  
([http://www.gs1.org/docs/gsmf/healthcare/GS1\\_Healthcare\\_GTIN\\_Allocation\\_Rules.pdf](http://www.gs1.org/docs/gsmf/healthcare/GS1_Healthcare_GTIN_Allocation_Rules.pdf))
3. GS1 DataMatrix Guideline  
([http://www.gs1.org/docs/barcodes/GS1\\_DataMatrix\\_Guideline.pdf](http://www.gs1.org/docs/barcodes/GS1_DataMatrix_Guideline.pdf))
4. Commission delegated regulation (EU) 2016/161  
([http://ec.europa.eu/health/files/eudralex/vol-1/reg\\_2016\\_161/reg\\_2016\\_161\\_en.pdf](http://ec.europa.eu/health/files/eudralex/vol-1/reg_2016_161/reg_2016_161_en.pdf))
5. ISO/IEC 15416 Information technology — Automatic identification and data capture  
([http://www.iso.org/iso/catalogue\\_detail?csnumber=27659](http://www.iso.org/iso/catalogue_detail?csnumber=27659))
6. ISO/IEC 15415 Information technology — Automatic identification and data capture  
([http://www.iso.org/iso/home/store/catalogue\\_tc/catalogue\\_detail.htm?csnumber=54716](http://www.iso.org/iso/home/store/catalogue_tc/catalogue_detail.htm?csnumber=54716))
7. ISO/IEC 15426 Information technology — Automatic identification and data capture techniques — Bar code verifier conformance specifications — Part 1: Linear symbols / Part 2: Two-dimensional symbols  
([http://www.iso.org/iso/catalogue\\_detail.htm?csnumber=57022](http://www.iso.org/iso/catalogue_detail.htm?csnumber=57022))
8. Amgros  
<https://levportal.amgros.dk/Sider/Default.aspx>

### 13. Appendix: Data structure for GS1 DataMatrix

Data in a GS1 DataMatrix barcode must comply with the GS1 data structure as noted in the GS1 General Specifications [1]. This encoded data structure must always begin with a FNC1 character. The FNC1 character is used to indicate to the decoding software that the data in the barcode has been encoded per the rules of the GS1 General Specifications.

This data format schema may contain a lot of different information. The most commonly used types of information in healthcare are GTIN, batch/lot number, expiration date and serial number.

Information is expressed in the form of Application Identifiers (AI) followed by the data. An Application Identifier is a number consisting of 2-4 digits, which indicates to the software processing the decoded data from the barcode scanner the meaning and format of the characters after the AI.

Table: Data formats for GTIN, batch number, expiry date and serial number

| Application Identifier | Information type      | Data format |
|------------------------|-----------------------|-------------|
| 01                     | GTIN (product number) | n2+n14      |
| 10                     | Batch number          | n2+X...20   |
| 17                     | Expiry date - YYMMDD  | n2+n6       |
| 21                     | Serial number         | n2+X...20   |

Explanation of table information:

n2: indicates the number of digits for the Application Identifier, example 01 for GTIN

n14: indicates how many digits the information after the Application Identifier must be, in this case 14 digits after 01

X...20: indicates that the batch and serial number can be both letters and numbers and up to 20 digits.

Example for data formatting:

GTIN: 5702830382244

Exp. date: 230901 = September 1, 2023

Batch number: BV1234

(01)05702830382244(17)230901(10)BV1234

**Note:**

When encoding data into certain GS1 barcodes (e.g. GS1 DataMatrix), a GTIN must be expressed as a 14-digit number. If the assigned GTIN is a GTIN-8, GTIN-12 or GTIN-13, respectively four, two and one leading zero must be added.

Application Identifier (10) – batch or lot number:

The application Identifier (10) indicates that the data field contains a batch or lot number. The batch or lot number associates an item with information the manufacturer considers relevant for traceability of the trade item to which the element string is applied. The number may be for example, a production lot number, a shift number, a machine number, or a time. The data is alphanumeric and has a variable length up to 20 characters [1].

Example: (10) BV1234

Application Identifier (17) - Expiration date:

Application Identifier 17 indicates that the data fields contain an expiration date. The expiration date is the date that determines the limit of use of a product. For pharmaceutical products, it will indicate the possibility of an indirect health risk resulting from the ineffectiveness of the product after that date.

The structure of the date is: year, year, month, month, day, day [1].

Example: (17) 230901 – September 1<sup>st</sup> 2023

Application Identifier - 21 – serial number:

Application Identifier (21) indicates that the data field contains a serial number. A serial number is assigned to an entity for its lifetime. When combined with the GTIN, a serial number uniquely identifies an individual item. The serial number field is alphanumeric and has a variable length up to 20 characters [1].

Example: (21) 24353638VB